

# STEP BEAM 5-SHELF UNIT /BLACK WRINKLE W/ MELAMINE SHELF

## WS184872BW-SB5MS

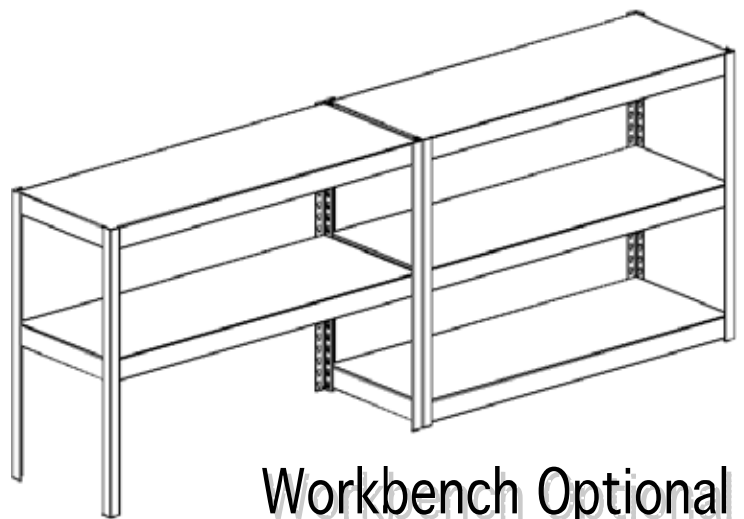
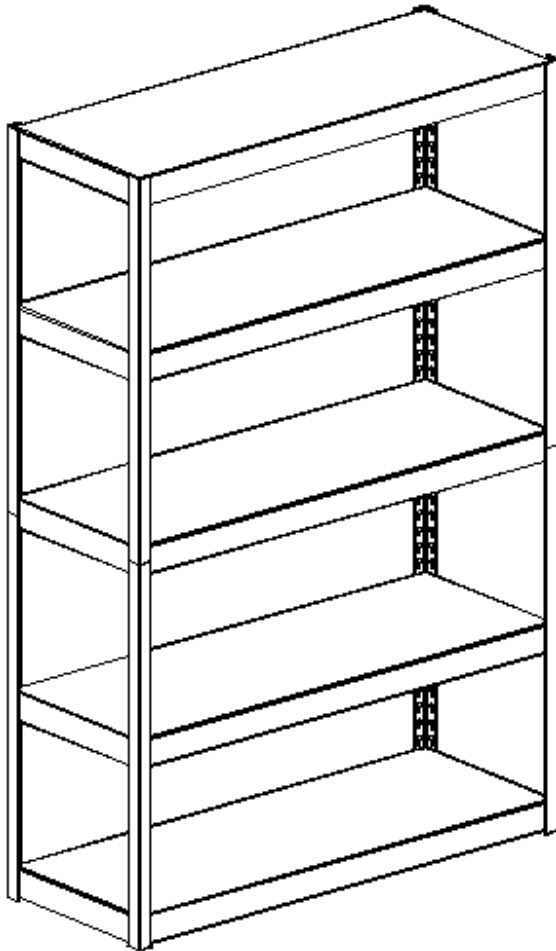

Workbench Optional

**“ADULT ASSEMBLY REQUIRED DUE TO THE PRESENCE OF SMALL PARTS, SHARP POINTS, SHARP EDGES”**



*Organize your life.*

Please call for replacement parts or assistance: **1-866-942-5362**

Pacific Standard Time: 8:30 am – 4:30 pm Monday to Friday

Or visit our web site [www.whalenstorage.com](http://www.whalenstorage.com)

Factory No.: 14400

Page # 1

## Parts List

Please read completely through the instructions and verify that all parts listed are present before beginning assembly.



A- Angle Post (8-ea.)



B- Long Double Rivet Beam (10-ea.)



C- Short Double Rivet Beam (10-ea.)

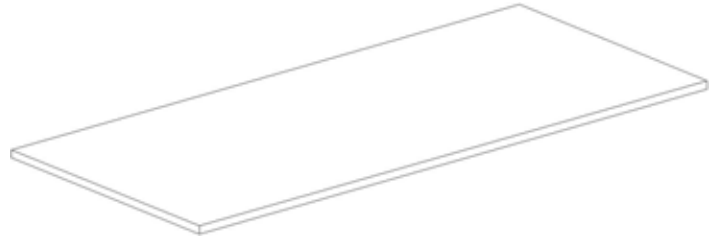

D- PB Shelf (5-ea.)

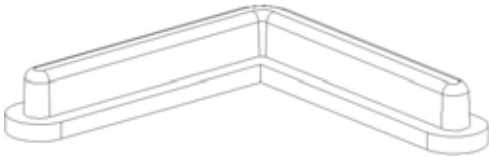

E- Post Cap (8-ea.)



F- Post Inserts (4-ea.)  
(Used on Storage Rack)



G- Post Clip (2-ea.)  
(Used on Workbench)

**Tool Required: Rubber Mallet, Hammer, Phillips Screwdriver, Power Drill**

**Please call for replacement parts or assistance: 1-866-942-5362**

**Factory No.: 14400**

**Page # 2**

## Assembly Instructions

**Note:** Assemble the unit on a sturdy and level surface. Avoid assembly on carpet. To facilitate assembly we recommend having two persons assemble the unit. If you do not understand these directions, or have any doubts about the safety of the installation, please call a qualified contractor or contact Whalen Storage at 1-866-942-5362. We can assist you or give you directions.

Make sure all the rivets locked in place before using the Work Bench, if you have any defective parts please do not use, improper installation may result in damages or injuries.

1. Unpack the unit and confirm that you have all the hardware and required parts listed.

### OPTION #1 STORAGE RACK

2. Start the end assembly by joining a Short Double Rivet Beam (part C) into the two bottom keyholes of a 36" Angle Post (part A). Be sure that the flange is up and drive the rivets to the bottom of the keyhole by hitting the beam with a rubber mallet. Repeat to add the second 36" Angle Post creating a Bottom End. As shown in detail #1.

Detail #1

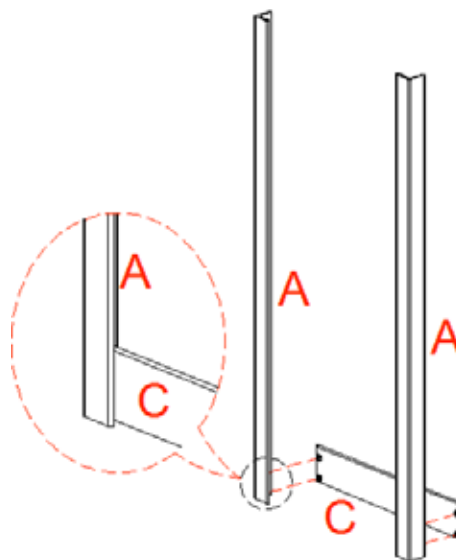

3. Assemble a Long Double Rivet Beam (part B) to the bottom keyholes of the bottom end assembly. Hit the beam with a rubber mallet to lock pieces together. Add the Angle Posts and Long Double Rivet Beam and lock pieces together until complete. All beam flanges must be up. As shown in detail #2.

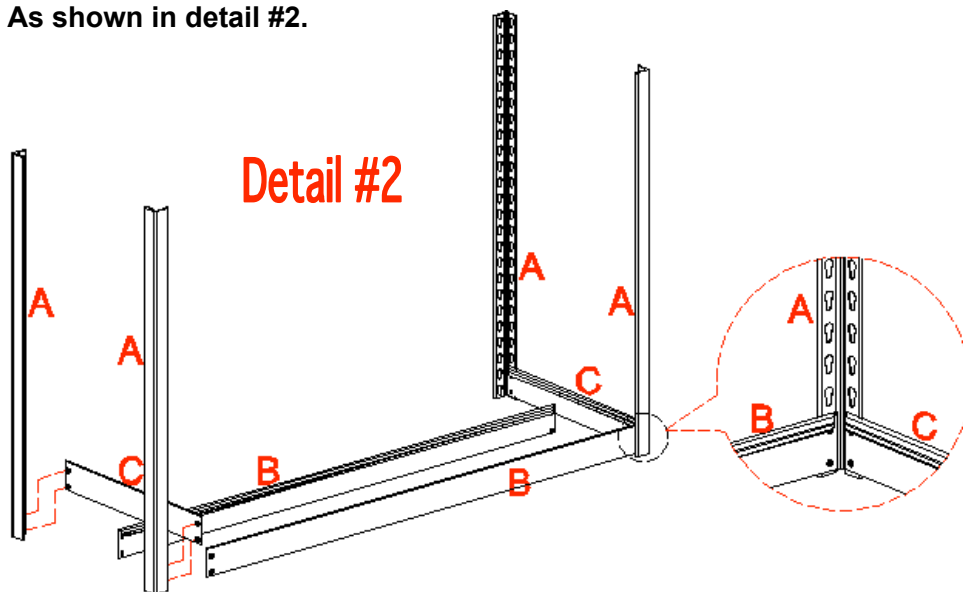

Please call for replacement parts or assistance: **1-866-942-5362**

Factory No.: 14400

Page # 3

## Assembly Instructions

4. Start top end assembly by joining a Short Double Rivet Beam (part C) into the top keyholes of a 36" Angle Post (part A). Add the second 36" Angle Post. Hit the beam close to joints to lock pieces together.

5. Repeat last step for the opposite side top end assembly.

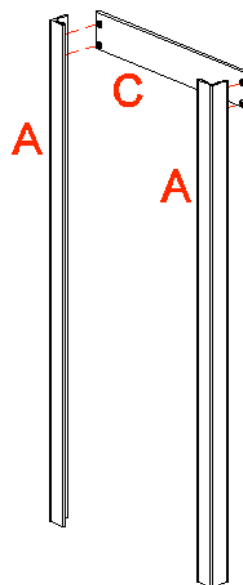

Detail #3

6. Before joining the top end assembly to the bottom frame assembly. Insert Post Inserts (part F) into the Angle Posts (part A) on the Bottom frame assembly. As shown in detail #4.

7. Repeat the last two steps for the opposite top end assembly.

Detail #4

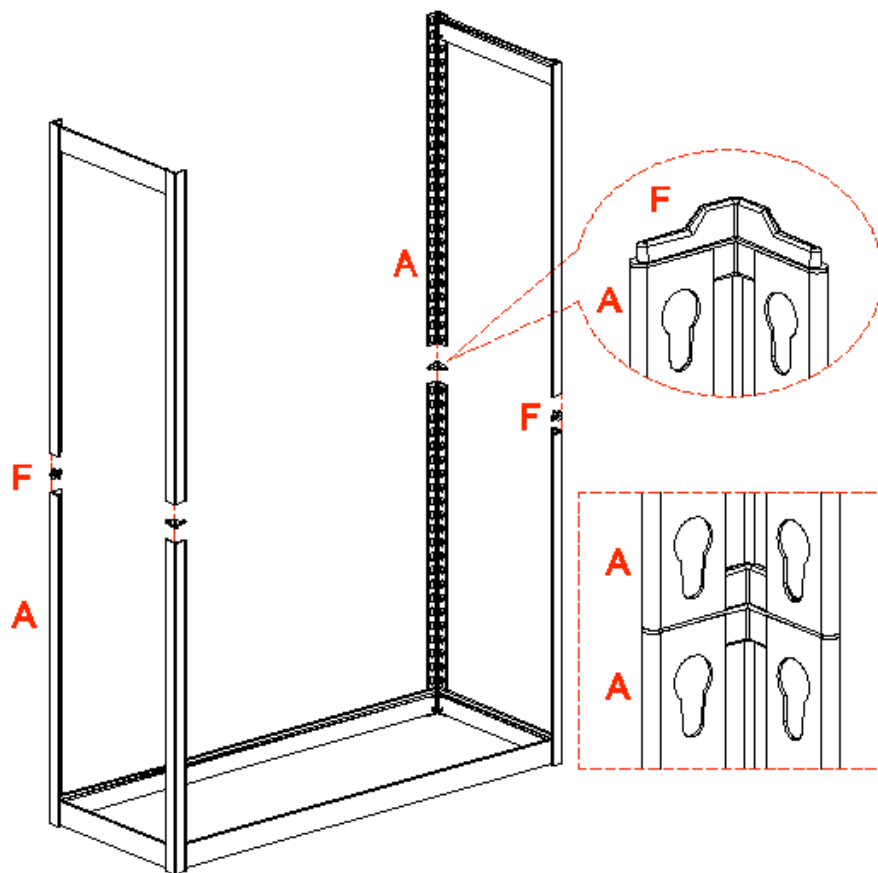

Please call for replacement parts or assistance: **1-866-942-5362**

Factory No.: 14400

Page # 4

## Assembly Instructions

8. Add two Long Double Rivet Beams (part B) to mid section. Be sure to use the bottom keyholes of the top assembly angle post and top keyholes of the bottom assembly. Follow the proper keyholes as shown in detail #5. Be sure to have all rivets in the keyholes before hitting the beam.

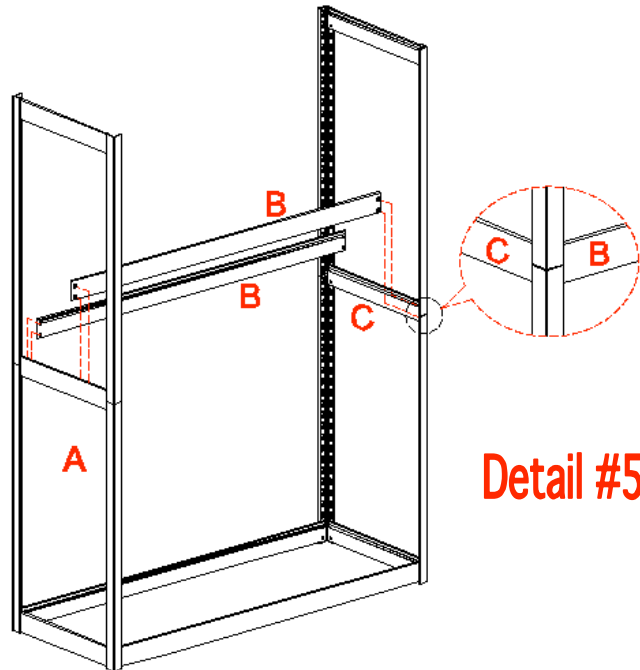

9. Add two additional Long Double Rivet Beam to top two keyholes of the angle post as shown. Be sure to have all rivets in the keyholes before hitting the beam. As shown in detail #6.

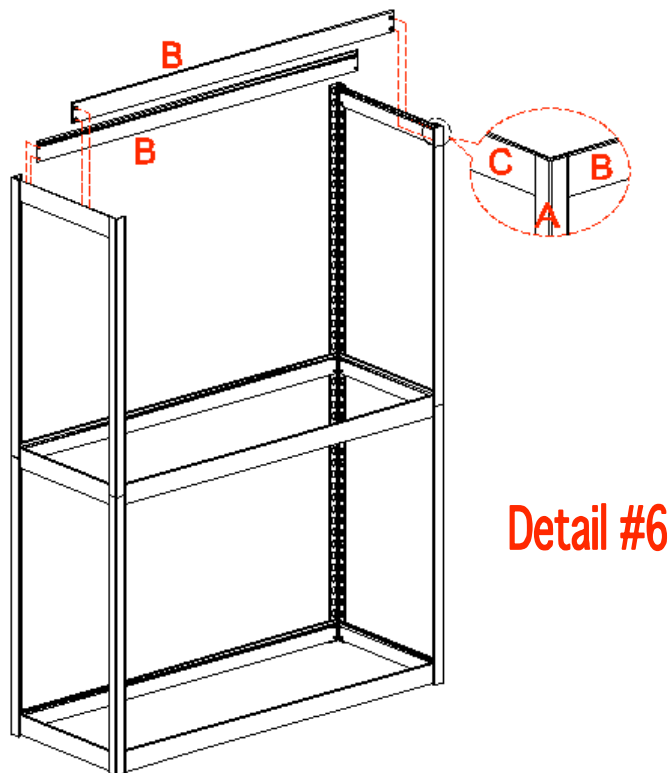

Please call for replacement parts or assistance: **1-866-942-5362**

Factory No.: 14400

Page # 5

## Assembly Instruction

10. Assemble the remaining Short and Long Double Rivet Beams to your desired location on the angle post. Hit Beams to lock pieces together. As shown in detail #7.

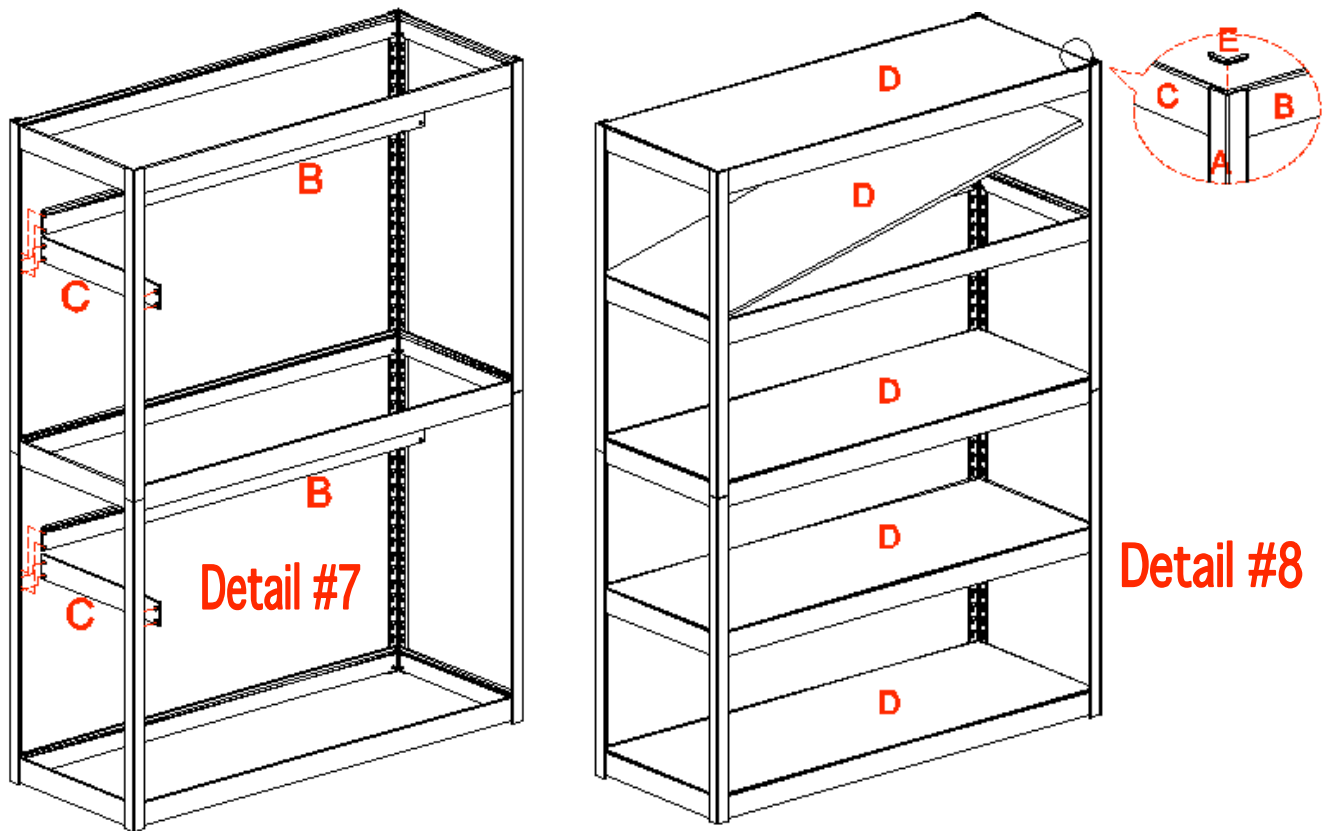

11. Add the Post Caps (part E) to the top and bottom of the 4 corner Angle Posts. As shown in the detail #8. Lay the shelf decks into place.

Please call for replacement parts or assistance: **1-866-942-5362**

Factory No.: 14400

Page # 6

## Assembly Instruction

### OPTION #2 WORK BENCH

12. Repeat step 2 through 3 to create bottom frame assembly.

13. Now add two Short Double Rivet Beams (part A) and two Long Double Rivet Beams (part B) to the top keyholes of the Angle Posts. Hit the beams near the joints with a rubber mallet to lock pieces together. As shown in detail #9.

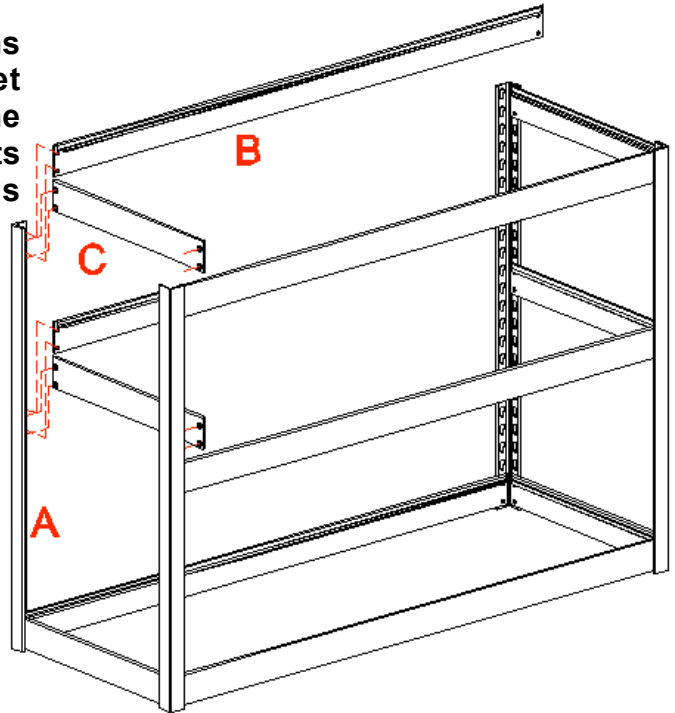

Detail #9

14. Start the add-on unit by joining a Short Double Rivet Beam (part C) into the top two keyholes of a 36" Angle Post (part A). Add an additional 36" Angle Post. Hit the beam with a rubber mallet to lock pieces together. As shown in detail # 10. Install the second Short Double Rivet Beam at your desired location on the posts.

15. Repeat the last step for the opposite end assembly.

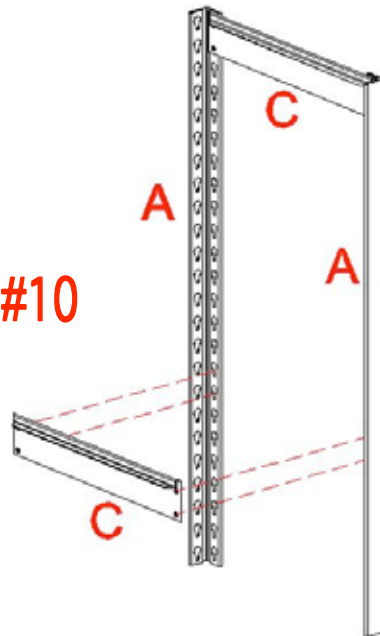

Detail #10

Please call for replacement parts or assistance: 1-866-942-5362

Factory No.: 14400

Page # 7

## Assembly Instruction

16. Complete the add-on unit by installing remaining Long Double Rivet Beams (part B). Make sure the Long Double Rivet Beams are flush with the Short Ones after installing. As shown in detail #11. Hit the beams near the joints with a rubber mallet to lock pieces together.

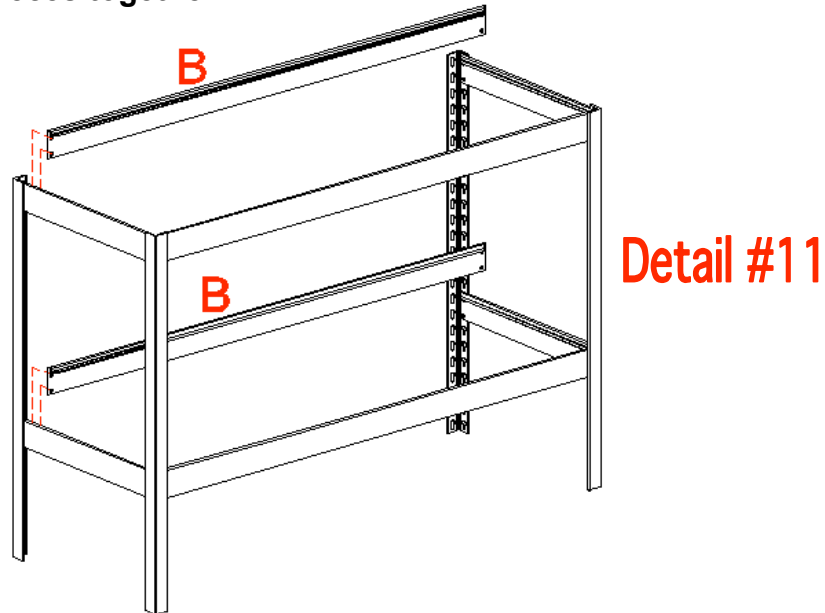

17. Now lay the Shelf Decks (part D) in places. And add Post Caps to the top of the angle Post. As shown in detail # 12.

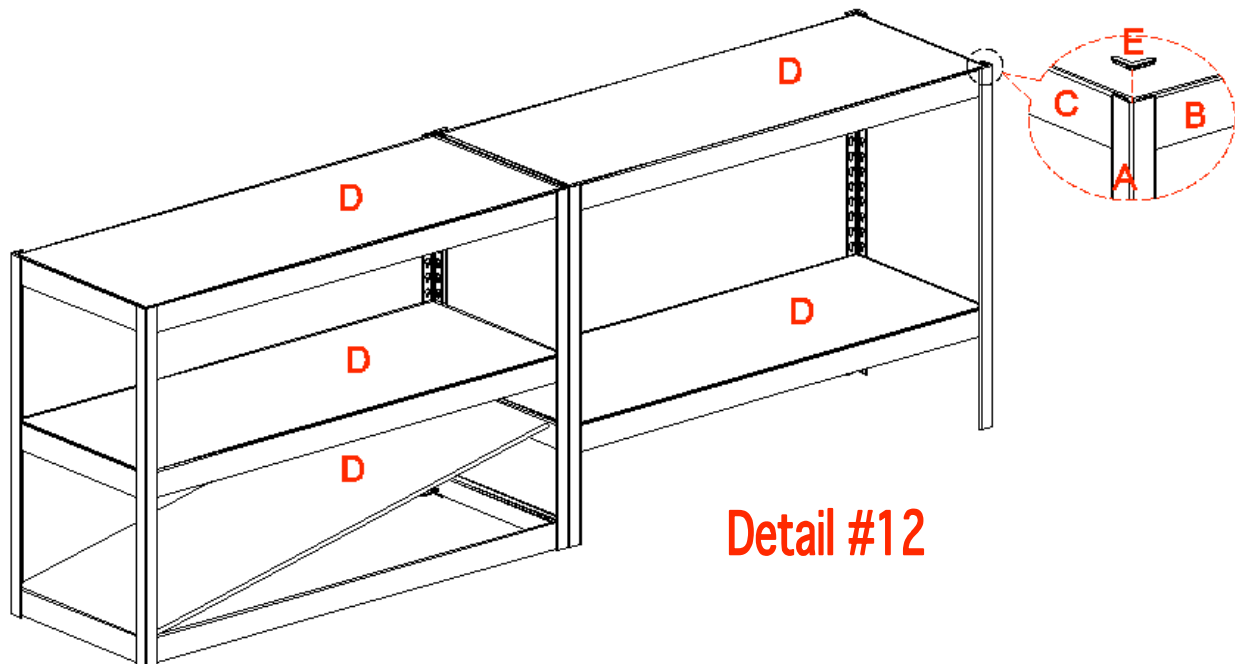

Please call for replacement parts or assistance: 1-866-942-5362

Factory No.: 14400

Page # 8

## Assembly Instruction

18. Place the two assembled units side by side, place Post Clip (part G) onto proper place and push in until they're seated firmly. As shown in detail #13. They're connected up with each other.

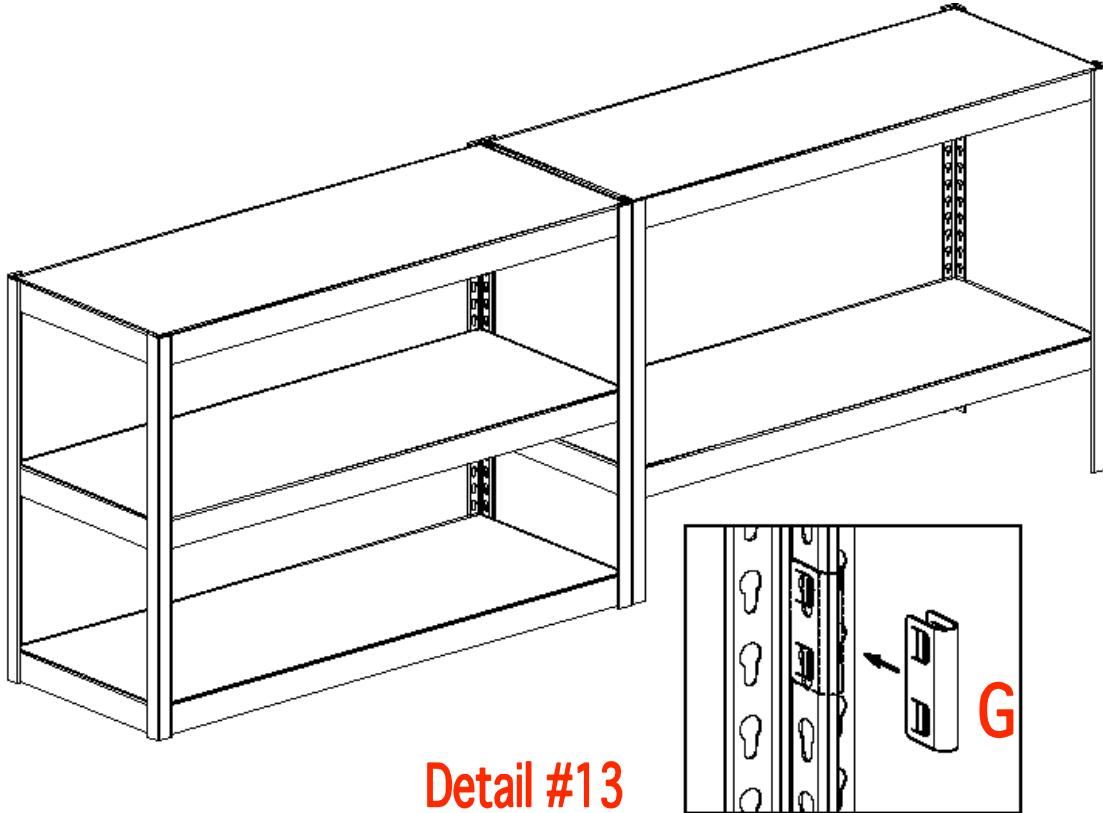

**“KEEP THESE INSTRUCTIONS FOR FURTHER REFERENCE”**

**Your assembly should now be complete.  
Thank you for your purchase.**



*Organize your life.*

[www.whalenstorage.com](http://www.whalenstorage.com)

**Please call for replacement parts or assistance: 1-866-942-5362**

**Factory No.: 14400**

**Page # 9**